

# ELECTRIC WATER HEATER

## 3.6kW AND 5kW

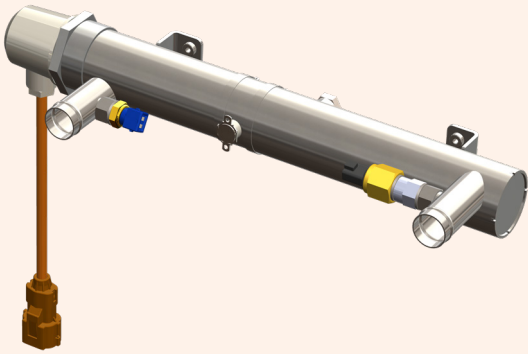

### PART NUMBERS:

3.6kW Electric Water Heater - 3C-6693-0A00

5kW Electric Water Heater - 3C-6694-0A00

## ELECTRIC WATER HEATER FEATURES

Whether you need to create a warm, comfortable and safe environment for passengers and/or drivers, or provide the optimum temperature for your vehicle's batteries, our Electric Water Heater can provide the solution.

Our electric water heater will deliver critical heat to your full electric, hydrogen or hybrid vehicles' drivers, passengers or batteries. Noise-free and completely emission-free, our high-performance heater range are the electric water heaters of choice for market-leading bus, coach, commercial vehicles, refuse trucks, off-highway and stationary power manufacturers.

### Key features

- Heat output either 3.6kW or 5kW @ 650VDC input voltage
- Built-in thermal protection for safety
- Ideal for remote installation or packaging as part of a complete system
- Optimises efficiency and life of batteries in cold climates
- Additional heating source in a heat pump when operating in low ambient conditions
- Manufactured with insulated body to minimise energy losses
- Lightweight and compact solution
- "Plug and Play" installation
- Zero maintenance
- Supplied with a standard high voltage electrical connector

## DIMENSIONS

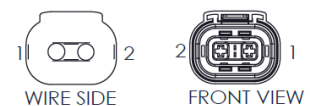
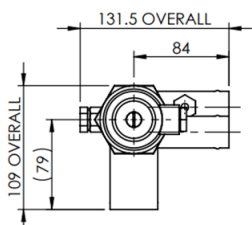
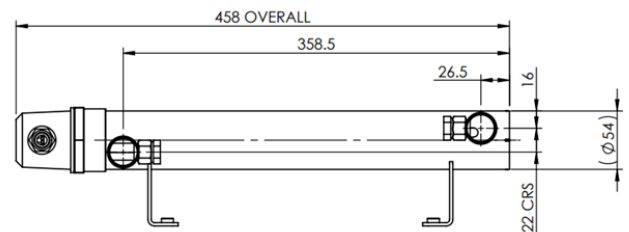
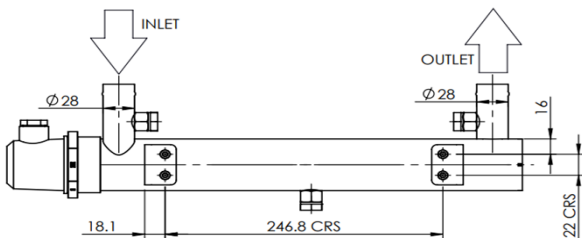

CAVITY No	COLOUR
1	RED
2	BLACK

# TECHNICAL INFORMATION

## Electric Water Heater (3.6kW and 5kW)

Water heating capacity @ 650VDC	3.6kW & 5kW
Working Temperature of the Liquid	-30°C to +80°C
Installation Temperature	-30°C to +50°C
Working Pressure	2 bar max
Minimum flow rate	15 l/min
Nominal Voltage	650V DC
Operating Voltage Range	300V - 800V DC
Nominal Power	3600W +5/-10% or 5000W +5/-10%
Maximum weight (without coolant) (kg)	3kg
External Dimensions (mm)	494mm (L) x 152mm (D) x 205mm (H)
Connector types (High Voltage (4-Pin))	TE Connectivity (PA66-GF35) Deutsch (HDP24/26)
Inlet & Outlet Size (mm)	28 mm
Ingress Protection / Rating	IP65
Harness Length (mm)	300mm
Heated medium	Cooling liquid/water ethylene glycol

Power vs Voltage for 3.6kW

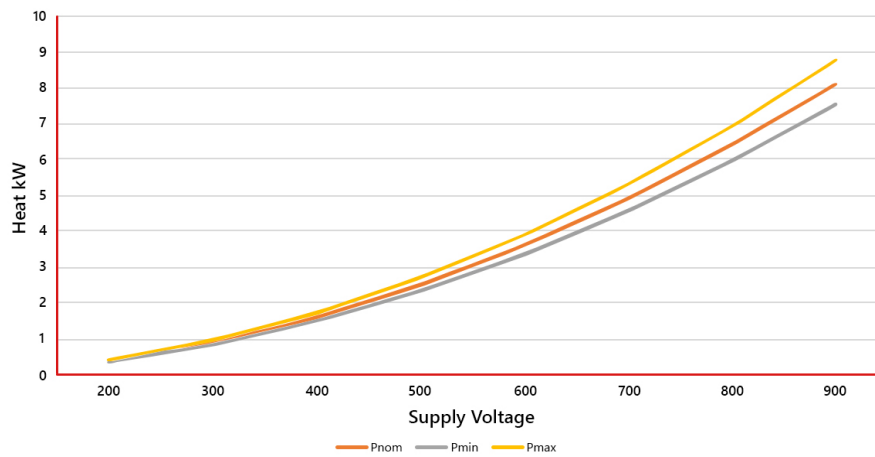

Power vs Voltage for 5kW

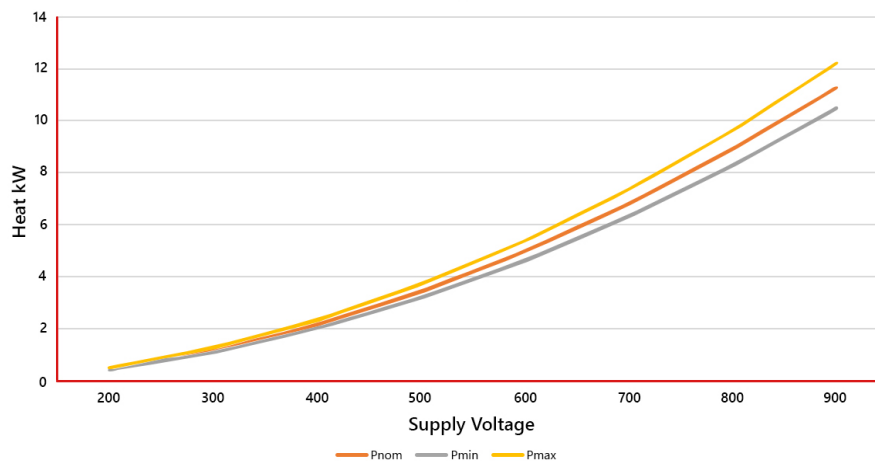

Enquire today

[www.graysonts.com](http://www.graysonts.com)

